

NOTE 1. () indicates a reference dimension.
 2. The connectors are delivered in bag packing.

1	PA	BLACK	UL94V-0
NO.	MATERIAL	FINISH. REMARKS	

UNITS mm			SCALE 4 : 1	COUNT △	DESCRIPTION OF REVISIONS	DESIGNED	CHECKED	DATE
HRS HIROSE ELECTRIC CO., LTD.		APPROVED : HS.OKAWA 06.11.13		DRAWING NO. EDC3-155943-00				
		CHECKED : HT.YAMAGUCHI 06.11.10		PART NO. FX15M-21P-C				
		DESIGNED : KN.SHIBUYA 06.11.10		CODE NO. CL575-2109-4-00				
		DRAWN : TH.KAMAI 06.11.08						

This connector requires careful handling. Please operate the connector with understanding of the following operation instructions.

Cautions for cable assembly

◆ Cable assembly conditions

It is recommended that prior to starting of the cable termination the following information be obtained from Hirose. All documents may be requested from the nearest Hirose sales office or agency.

1. Crimping operation basic instruction (Basic information about cable assembly)
2. Instruction Manual-Contact crimp termination (Description of the press)
3. Installation Table-Applicator parts (Installation instruction-Applicator)
4. Table of crimp conditions (Crimp height, Tensile strength)
5. Manual of Crimp Quality Standards (Bell-mouth dimensions, Bend up/down, Rolling, others)

Follow the instructions in the documents for proper cable assembly.

◆ Crimped contact insertion

Insert the crimped contacts straight, aligning the faces of the housing lance and the metal latch as shown in the figure. Insertion will not be completed without the alignment. It may also cause the deformation of the crimped contacts or the damage to the housing.

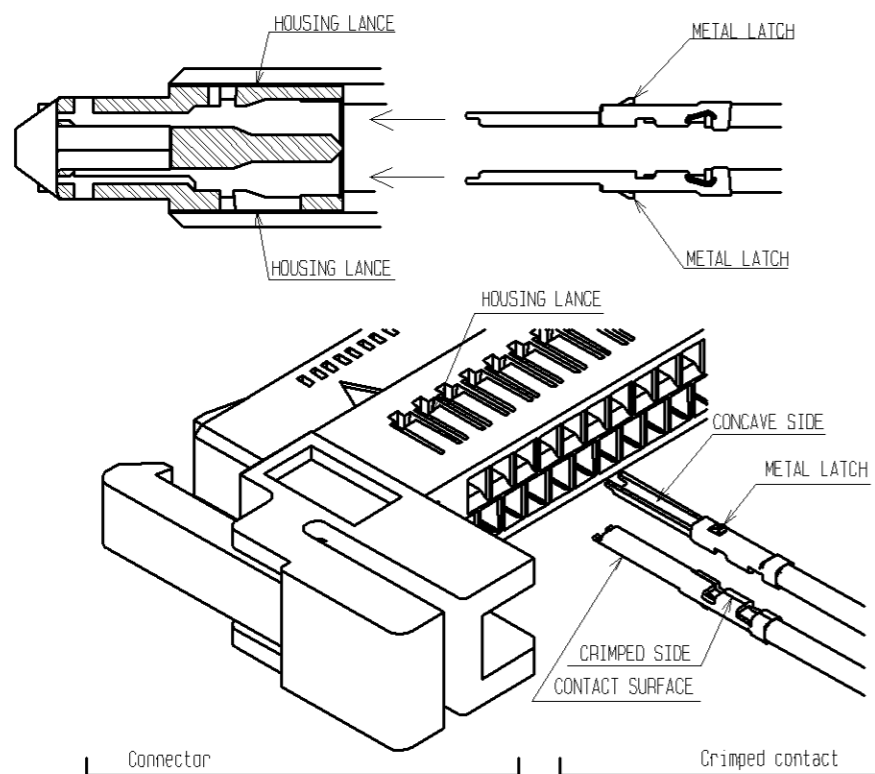

◆ Insertion confirmation of crimped contact

To confirm the proper contact insertion, check the position of the metal latch through the housing lance opening. With the contact properly inserted, the metal latch is positioned where it has completely passed through the housing lance.

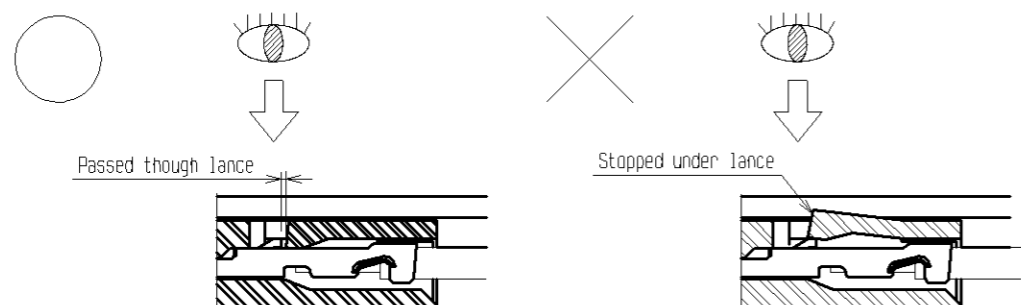

When the cable needs to be pulled for the check, make sure that the applied force is 3 N or lower. Excessive pulling of the cable may damage the housing lance, resulting in the deterioration of the lance retention force.

◆ Repair of crimped contacts

To extract the crimped contact after insertion, pull the cable, with lifting the housing lance with a pointy tool such as a needle. The repair work may have reduced the lance retention force. Therefore, do not reuse the repaired connector. Prepare a new connector.

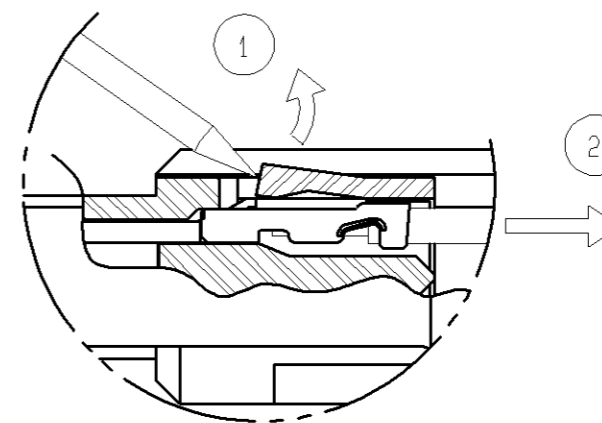

Cautions for mating with on-board connector

◆ Insertion to on-board connector

The connector mating is keyed. Align the marks as shown in the figure for mating. Insert the connector completely until they are locked at both ends. The connectors have a reverse-insertion prevention structure, however, the connectors may be damaged when inserted reversely with the force of 25 N or more. Avoid a forceful insertion, and make sure to confirm that the connectors are aligned with the marks before the mating operation.

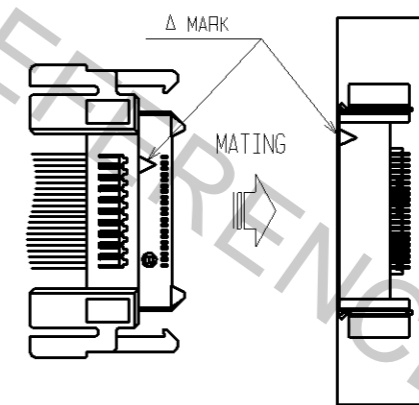

Note: The connectors shown in this "INSTRUCTION MANUAL" are drawn for the instruction purpose, therefore, the appearance differs from the actual connectors. Please confirm the connector configuration on the connector drawing (SHEET 1).

INSTRUCTION MANUAL

HRS	DRAWING NO.	EDC3-155943-00
	PART NO.	FX15M-21P-C
	CODE NO.	CL575-2109-4-00

◆ After mating

Carefully wire cables, so that excessive force will not be applied to the mated connectors. Especially, pulling a single cable with the force of 4 N or more may cause the cable (crimped contact) to fall out. Also, pulling a whole set of cables with the force of 20 N or more may damage the connectors. Take a caution to avoid pulling the cables.

◆ Withdrawal from on-board connector

The connectors are locked while they are mated. In order to unmate the connectors, pull the connector straight, with releasing the lock by pushing both sides of the connector. At this time, do not pull the cable. Also, avoid the withdrawal in angle, which may damage the connectors.

<Proper withdrawal>

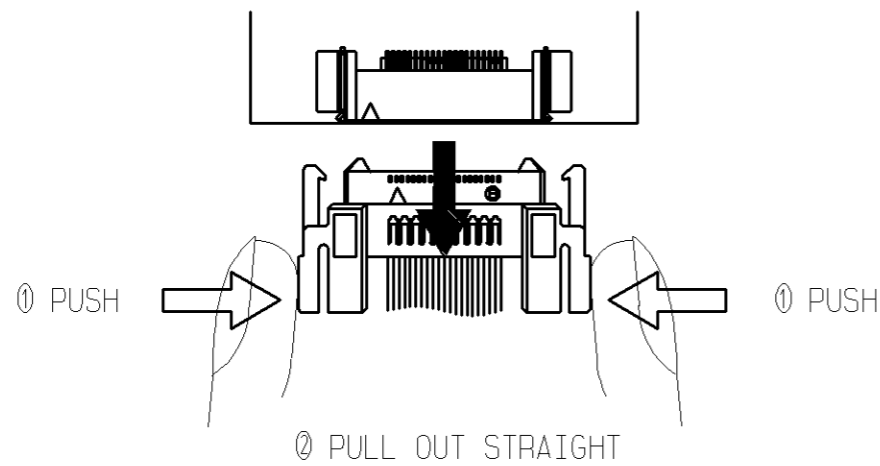

<Improper withdrawal>

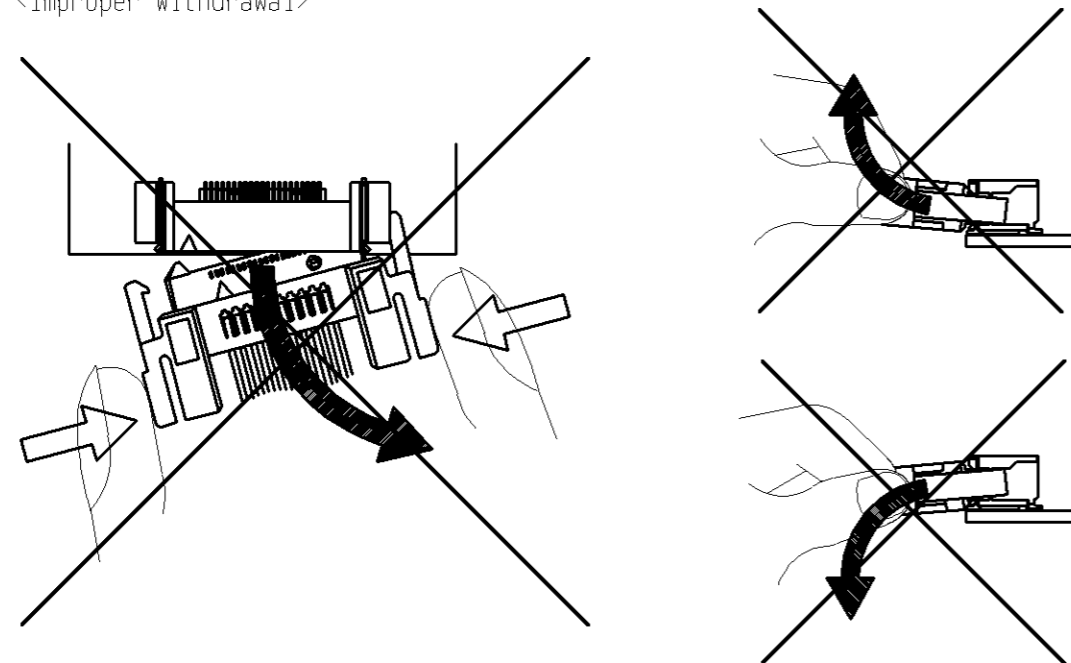

◆ Moving parts for lock mechanism

Excessive lock release operation to this single unit except for the purpose of connector withdrawal and direct action to the lock hook by fingers and such may damage the connectors.

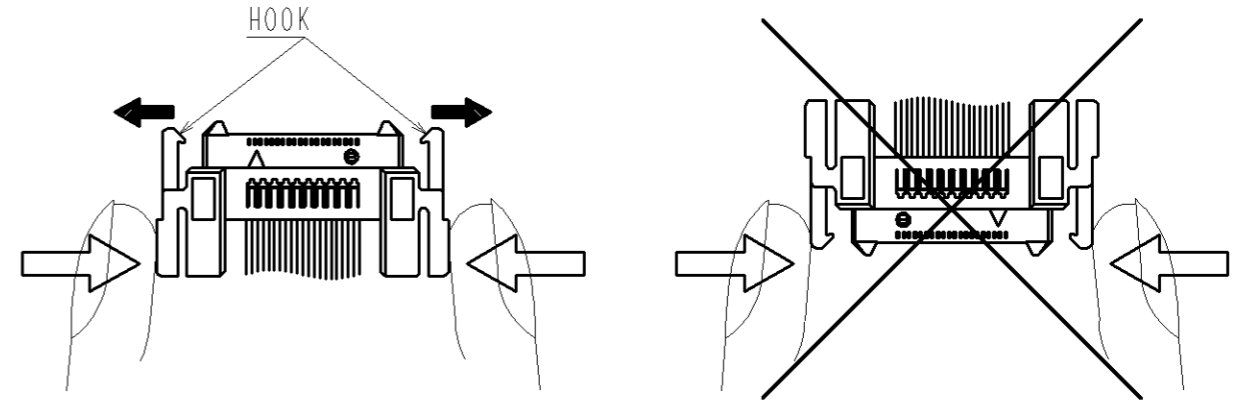

Note: The connectors shown in this "INSTRUCTION MANUAL" are drawn for the instruction purpose, therefore, the appearance differs from the actual connectors. Please confirm the connector configuration on the connector drawing (SHEET 1).

INSTRUCTION MANUAL

HRS	DRAWING NO.	EDC3-155943-00
	PART NO.	FX15M-21P-C
	CODE NO.	CL575-2109-4-00
		△ 3/3